



US5GMe—US5GM

ENABLING NEXT GENERATION CARRIER NETWORK SYNCHRONIZATION ...

FEI, with a 40-year legacy in precision oscillator technologies and more than 15 years of experience designing and manufacturing SSU's for major international carriers, has created an SSU of unprecedented.

- ◆ Reliability
- ◆ Durability
- ◆ Survivability
- ◆ Adaptability
- ◆ Cost efficiency

System Software Control Features

- ◆ Standard compliant TL-1 Command Line Interface
- ◆ Auto-provisioning of all modules during installation and initialization
- ◆ Upon insertion of a replacement module :
 - Automated Hardware and Software compatibility checks
 - Automated Software download of current module software
 - Auto-provisioning from current provisioning database
- ◆ Inventory in software:
 - Input reference source
 - Output port assignment
- ◆ Inventory CLEI and Mfg Serial Number in software to help in field servicing and PCN administration

TOTAL SOFTWARE MANAGEMENT

For the first time NO dedicated hardware assemblies, jumpers, or switches are used to configure common telecom signal formats in the US5GMe - inbound or outbound.

REMOTE MANAGEMENT

All software management interfaces are remotely accessible via TCP/IP LAN allowing full utilization of Centralized Network Operations Center (CNO) for monitoring and management.





US5GMe PRODUCT SPECIFICATIONS

Modular Redundancy in Hardware

- ◆ Dual Power Inputs & Power Supplies
- ◆ Up to 5 References Inputs
- ◆ Inputs bridge to both IOP Modules
- ◆ Dual IOP's (ST-2 or ST-3E)
- ◆ Paired Output Modules for 1 to 1 Protection

Microprocessor Control & Memory Features

- ◆ Top level Intel™ microprocessors on COM and both IOP modules
- ◆ System Databases stored on the COM module are backed up on BOTH IOP's
- ◆ Output Module on-board microprocessors enable management to each output port

Oscillator Options

- ◆ Standard Quartz ST-3E & Rubidium ST-2
- ◆ Optional Stratum 2 High Precision Double Oven Quartz Oscillator (DOCXO) - ST-2 performance at lower cost

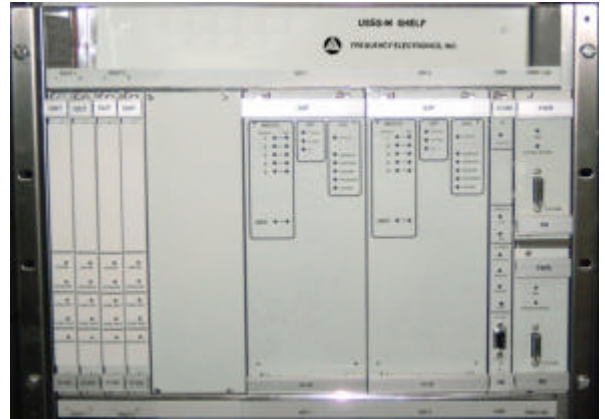

System Communications Interfaces

- ◆ Local craft interfaces—2 (1 front panel)
- ◆ TCP / IP Local Area Network interface via RJ-45

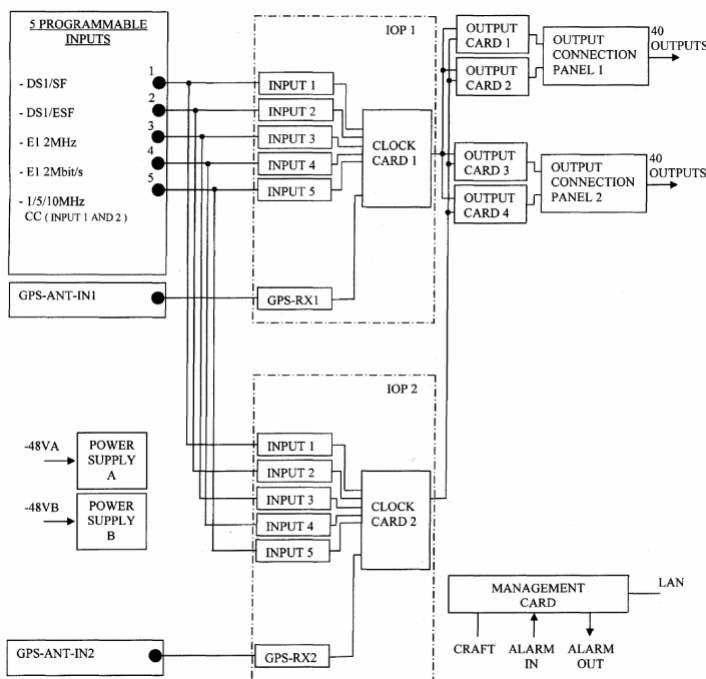

Integrated GPS Receiver

The US5GMe is designed to integrate GPS receiver. This arrangement optimizes rack bay utilization by eliminating separately mounted GPS unit. The GPS reference is independent of other input capacity meaning all other inputs are still available for selection or for monitor only operation.

Alarm Reporting Modes

- ◆ Module Status and Alarm LED's
- ◆ 6 Contact Closure Relays—Local & Remote
- ◆ TL-1 Autonomous Output Messaging
- ◆ 16 Discrete Alarm Input Relays



US5GMe PRODUCT SPECIFICATIONS

Architecture

Main shelf module : 2 clocks with maximum 3 inputs each, GPS, 4 output cards (80 1+1 max output ports)
Fast interface bus for inter-cards communication
Local and remote management; software download for all active module (IOP modules, COM card, Output Cards)
Safe Data Base management; duplication of Data base on COM card and on both clock modules

Power supply modules

Dual load sharing
Each receives power from dedicated back panel power input
Automatic redundancy in case of module failure
Dual -35 to -72VDC

Communication Module (COM card)

System Communications Controller -BOTH external and internal processes
Provides system TL-1 Agent
Manages all system security processes
Manages all DB storage, access & synchronisation with IOP back up
Powerful CPU with real time kernel.
2 RS232: CRAFT 1,2
1 ETHERNET RJ45: 4x TELNET + 6x TCP/IP sessions
EVENT LOG (1000)
EVENT AO LOG (400)
SECU LOG (100)
DBCHG LOG (400)
Performance measurement : buffering, log and alarm for Clock module PM data

Clock modules (IOP modules)

Based on Rubidium or quartz oscillator, possibility of mixed configuration
Dual redundant clock modules
Clock performance : ITU-T G.812 type 1 & 2 or ANSI T1.101 type ST2 or ST3E
5 Universal input modules : E1, 2048 kHz, 1-5-10 MHz, (option 1544 kHz, DS1, 64 kHz CC)
Maximum 5 input modules per clock module (input impedance 75 and 120 Ohm)
Each input can be used as reference or measurement input
SSM: full compliant (ITU-T G.704, Telcordia GR-378), possibility of QL assignment for no SSM capable inputs
Full software manageable: diagnostic alarms, automates for clock state administration
Powerful CPU with real time kernel
Performance Measurement : TIE, MRTIE, TDEV, FFOFF for several time intervals (1s to 10000s)

GPS

Two plug-in GPS receivers
Optionally, antenna converter allowing to use 300m of RG59 cable to connect the antenna

Output

40 or 20 outputs per module, paired for 1+1 protection
E1 2MHz-2Mbit/s programmable or T1-CC programmable
Main shelf: 80 outputs max (1+1 protected)

Environmental

Operating temperature: -5° to 50°c
Humidity: 5 to 95%
Dimensions: H=270mm(10.5"); W=430mm(17"); D=280mm(11")
NEBS level 3