



# US5Ge - Protected Outputs

## ENABLING NEXT GENERATION CARRIER NETWORK SYNCHRONIZATION ...

FEI, with a 40-year legacy in precision oscillator technologies and more than 20 years of experience designing and manufacturing SSU's for major international carriers, has created an SSU of unprecedented.

- ◆ Reliability
- ◆ Durability
- ◆ Survivability
- ◆ Adaptability
- ◆ Cost efficiency

### **TOTAL SOFTWARE MANAGEMENT**

For the first time NO dedicated hardware assemblies, jumpers, or switches are used to configure common telecom signal formats in the US5Ge - inbound or outbound.

### **REMOTE MANAGEMENT**

All software management interfaces are remotely accessible via TCP/IP LAN allowing full utilization of Centralized Network Operations Center (CNO) for monitoring and management.

### **System Features**

- ◆ Auto-provisioning of all modules during installation and initialization
- ◆ Upon insertion of a replacement module :
  - Automated Hardware and Software compatibility checks
  - Automated Software download of current module software
  - Provisioning from current database
- ◆ Inventory in software:
  - Input reference source
  - Output port assignment
- ◆ Inventory and Mfg Serial Number in software to help in field servicing and PCN administration
- ◆ TL-1 Command Line Interface
- ◆ SNMP protocol
- ◆ NTP client/server card (hardware assistance, 2 LAN ports)
- ◆ Protected Output cards :
  - E1 + 2.048 MHz card (20/40 ports)
  - DS1 + CC card (20/40 ports)





## Modular Redundancy in Hardware

- ◆ Dual Power Inputs & Power Supplies
- ◆ Up to 10 References Inputs
- ◆ Inputs bridge to both IOP Modules
- ◆ Dual GPS Reference Receivers (Optional)
- ◆ Dual GPS Antenna Inputs
- ◆ Dual IOP's (ST-2 or ST-3E)
- ◆ Dual Redundant umbilicals directly connected to each expansion shelf

## Microprocessor Control & Memory Features

- ◆ Top level Intel™ microprocessors on COM and both IOP modules
- ◆ System Databases stored on the COM module are backed up on BOTH IOP's
- ◆ Output Module on-board microprocessors enable management to each output port

## Oscillator Options

- ◆ Standard Quartz ST-3E & Rubidium ST-2
- ◆ Optional Stratum 2 High Precision Double Oven Quartz Oscillator (DOCXO) - ST-2 performance at lower cost

## System Communications Interfaces

- ◆ 3 Local craft interfaces (1 at the front panel)
- ◆ TCP / IP Local Area Network interface via RJ-45

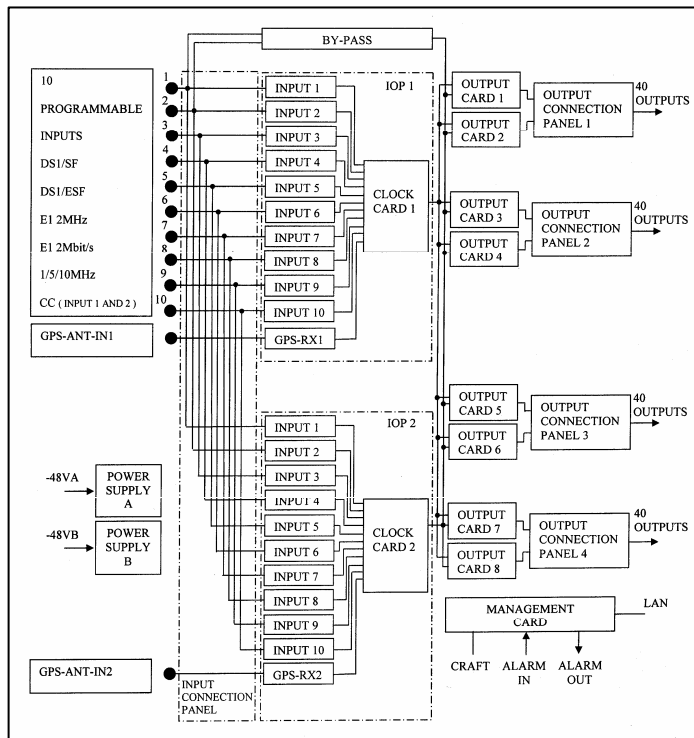
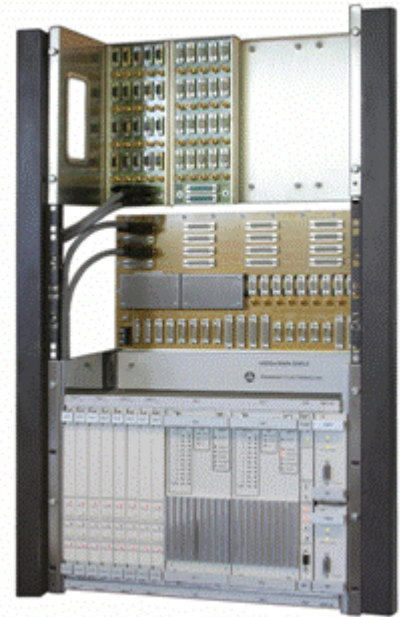

## Integrated GPS Receiver

The US5Ge is designed to integrate two GPS receivers. This arrangement optimizes rack bay utilization by eliminating separately mounted GPS units. The GPS references are independent of other input capacity, meaning all other inputs are still available for selection or for monitor only operation.

## Alarm Reporting Modes

- ◆ Module Status and Alarm LED's
- ◆ 6 Contact Closure Relays—Local & Remote
- ◆ TL-1 Autonomous Output Messages
- ◆ SNMP Traps
- ◆ 16 Discrete Alarm Input Relays
- ◆ Alarms reported for Expansion shelf umbilicals & BYPASS module faults



# US5Ge - Protected Outputs PRODUCT SPECIFICATIONS

## Architecture

Main shelf : 1 COM card, 2 power supplies, 2 IOP clocks with maximum 10 inputs each, 2 GPS, 8 output cards (max 160 1+1 output ports)  
Optional: Bypass module (third clock for emergency situation)  
Up to 4 expansion shelves: 2 power supplies, 16 output cards (max 320 1+1 output ports) per shelf  
Fast interface bus for inter-cards communication  
Local and remote management; software download for all active modules (IOP modules, COM card, Output Cards)  
Safe Data Base management; duplication of Data base on COM card and on both clock modules

## Power supply modules

Dual load sharing  
Each receives power from dedicated back panel power input  
Automatic redundancy in case of module failure  
Front panel fuses and power status led's  
Dual -35 to -72VDC

## Communication Module (COM card)

System Communications Controller -BOTH external and internal processes  
Supports TL-1 and SNMP agents for equipment supervisory  
Manages all system security processes  
Manages all DB storage, access & synchronisation with IOP back up  
Powerful CPU with real time kernel.  
3 RS232: CRAFT 1,2,3  
1 ETHERNET RJ45: 4x TELNET + 6x TCP/IP sessions  
EVENT LOG (1000)  
EVENT AO LOG (500)  
SECU LOG (500)  
DBCHG LOG (500)  
SNTP & NTP stratus 1 on board (request GPS option)  
Performance measurement : buffering, log and alarm for Clock module PM data

## Clock modules (IOP modules)

Based on Rubidium or quartz oscillator, possibility of mixed configuration  
Dual redundant clock modules  
Clock performance : ITU-T G.812 type 1 & 2 or ANSI T1.101 type ST2 or ST3E  
Universal input module : E1, DS1, 1-5-10 MHz, 1544 KHz, 2048 kHz, 64 kHz CC  
Maximum 10 input modules per clock module (input impedance 75 and 120 Ohm)  
Each input can be used as reference or measurement input  
SSM: full compliant (ITU-T G.704, Telcordia GR-378), possibility of QL assignment for no SSM capable inputs  
Full software manageable: diagnostic alarms, automates for clock state administration  
Powerful CPU with real time kernel  
Performance Measurement : TIE, MRTIE, TDEV, FFOFF for several time intervals (1s to 10000s)

## GPS

Single or dual GPS modules  
Dual Antennas inputs  
GPS input with or without long distance cable interface (antenna converter)

## Outputs

E1 + 2.048 MHz Protected card (20/40 ports)  
DS1 + CC Protected card (20/40 ports)  
NTP client/server card (hardware assistance, 2 LAN ports)

## Environmental

Operating temperature: 0 to 50°C  
Humidity: 5 to 95%  
Dimensions: H=270mm; W=430mm; D=280mm  
NEBS level 3  
ROHS Compliant